

MARTIAN HABITAT

1:1 INTERACTIVE ARCHITECTURE PROTOTYPES



GROUP 1

DIYA SHARMA

GRAYSON RYAN

ZIXIONG WAN

ANN AN

YUQUING ZHANG

INTRODUCTION

As aerospace technology advances, the prospect of human habitation on Mars has become increasingly feasible. Nicholas (2017) notes NASA and SpaceX's ambitions to send humans to Mars by 2030 and 2040, respectively. In response to this growing interest, the Martian Habitat project aims to design architectural solutions for sustainable living on the Red Planet. Tailored for 2-3 research scientists, the habitat is envisioned as a space for exploration and study, particularly focused on investigating the presence of water. Emphasizing efficiency, safety, and adaptability, the habitat integrates innovative human-robot interaction methods. This approach not only ensures the successful execution of tasks, from construction to daily operations, but also lays the groundwork for future colonization efforts. Leveraging local resources such as Regolith, the project explores cutting-edge technologies like Design-to-Robotic-Production-Assembly, Computer Vision, and Human-Robot Collaboration, signaling a promising step towards sustainable living beyond Earth.

CONDITIONS ON MARS

Constructing habitats on Mars presents a unique set of challenges due to the planet's harsh environment and distance from Earth. Some construction challenges on Mars include:

- Atmospheric conditions: Mars has a thin atmosphere composed mostly of carbon dioxide, with occasional dust storms. These conditions can impact construction materials and techniques, requiring adaptations to ensure structural integrity.
- Extreme temperatures: Mars experiences wide temperature fluctuations, with average temperatures around -80 degrees Fahrenheit (-62 degrees Celsius). Materials and equipment must withstand these extreme conditions to maintain functionality and structural stability.
- Radiation exposure: Mars lacks a strong magnetic field and thick atmosphere to shield against solar and cosmic radiation. Constructing habitats that provide sufficient radiation protection for long-term human habitation is crucial. Long-term habitats should be equipped with radiation shielding, thick enough to reduce the radiation to a level equal to Earth, that is, almost zero. Best protection may be achieved with houses built in natural caves or set into cliffs or hillsides. Any matter placed between a person (or radiation-sensitive equipment) and a radiation source reduces the amount of radiation they absorb. Mars One's solution is a thick layer of regolith on top of the settlement modules. (Marspedia 2022).
- Dust and regolith: Mars is covered in fine dust and regolith, which can pose challenges for construction equipment, machinery, and seals. Minimizing dust infiltration into habitats and preventing equipment degradation are significant concerns. "Dust storms, cosmic rays and solar winds ravage the Red Planet's surface. But belowground, some life might find refuge" says Nikk Ogasa in the article Martian crust could sustain life through radiation (Ogasa).

SITE

Based on research of Mars environmental condition and findings by previous groups, we've chosen to build the habitat underground within a crack on Mars to shield it from cosmic waves and radiation. Sealing the cracks is vital to prevent dust infiltration and regulate internal temperatures, requiring specialized materials and techniques. Constructing in this rugged terrain demands resilient systems adaptable to Martian geology, while careful assessment of risks like seismic activity is essential for safety.

The site is located in the large rift system on Mars known as the Valles Marineris. Deep gullies and valley-like formations on the edge of the Lus Chasma indicate possible erosion by flowing water. Other formations and sediments also indicate the former presence of liquid water; therefore, the location was

more suitable for design. There is also presence of a chaotic terrain consisting of cracks in the Pyrrhae Region the Valley region that could be used for the design development.

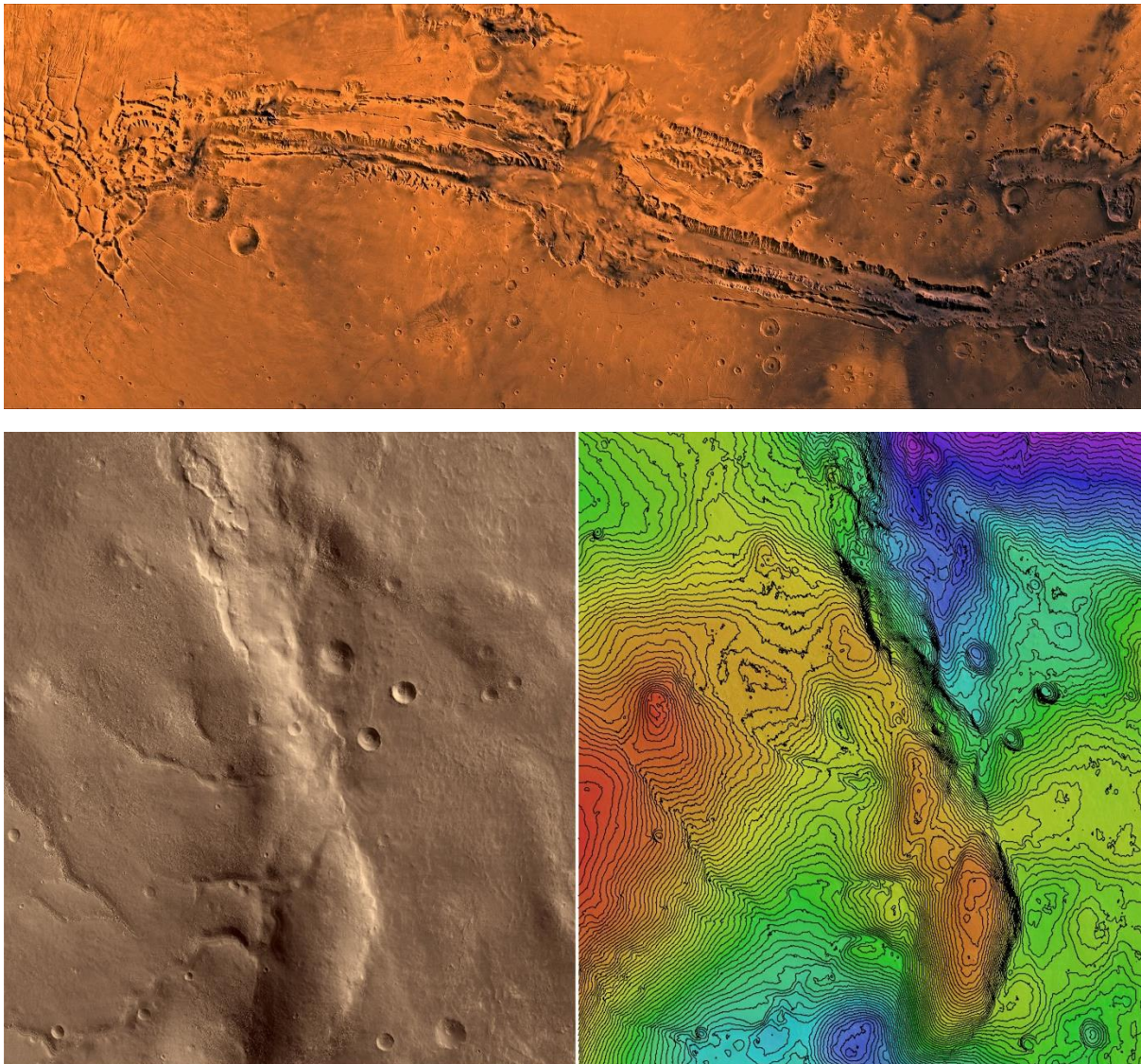

Fig 1. Valles Marineris Mars (Wikipedia)

CASE STUDIES

The research of Mars environmental conditions and findings of rhizome 0.1 by TU Delft's architectural group, suggested construction underground using local regolith to shield it from cosmic waves and radiation. Their study on construction between cracks suggested optimizing the site conditions while providing protection. While beneficial, this focus on building within cracks necessitated further exploration into establishing sustainable habitats within them. Stefano Boeri, an Italian Architect (2017), suggested plant-covered towers as a solution for urban habitats on Mars, inspiring ideas for greenhouse design within the structures. Additionally, DECA Architecture's (2019) project on the Greek Island of Milos, employing Voronoi cells to design habitats, offered practical insights for design refinement.



Fig 2. a. Settling between cracks (Behboodi et al, 2023); b. Stefano Boeri (2017) Mars with plant towers; c. DECA Architecture (2019) Voronoi design

CONCEPT

The design aimed to maximize the utilization of natural cracks on Mars, which inherently function as shelters against the planet's storms and radiation. Consequently, the form was conceived as a vertical structure nestled within these cracks. Leveraging the verticality, we integrated our vision of a green buffer space by incorporating an atrium into the structure.

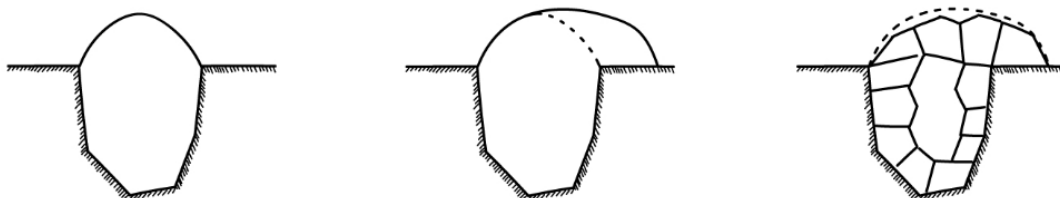

We chose natural cracks as a site. We placed the entrance at ground level. Generating Voronoi cells in cracks.

Fig 3. Design approach in the Cracks

DESIGN DEVELOPMENT

We initially envisioned a structure constructed from carbon fiber that could securely adhere to the inner surface of the crack, ensuring structural integrity. However, we soon recognized the practicality of utilizing the locally abundant regolith material to encase the entire design. Consequently, we proceeded with the design based on this premise. The private spaces seamlessly intertwine with the central atrium, facilitating connectivity to the buffer space.

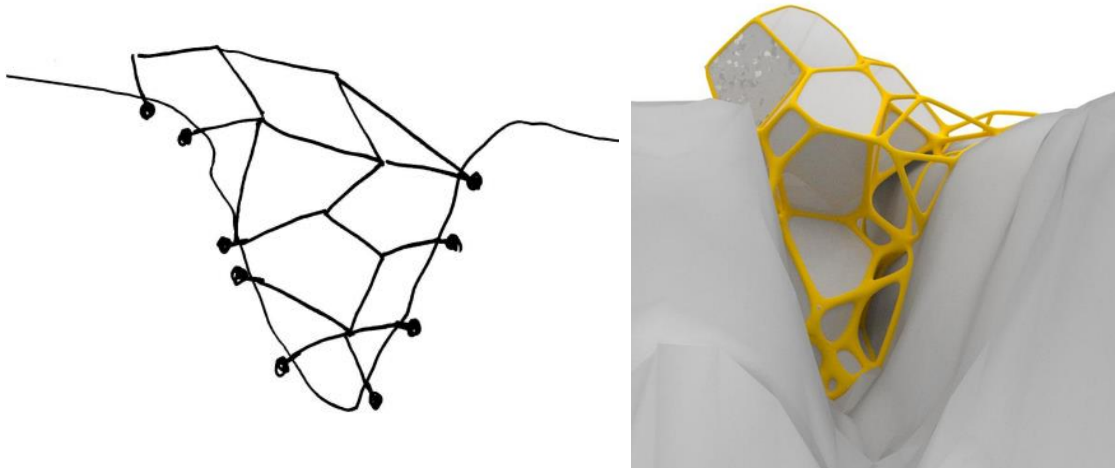

Fig 4. Initial Structure design

The design was developed to have air lock Entrance on the ground with workspaces above the ground for easy access and drone landing. All the dwelling units were placed within the crack and around the atrium to protect from radiation while have an open central buffer space. The atrium has set of connecting staircases that form continuity within the design. All the spaces are designed with the Voronoi concept generated through the grasshopper script. Part of the structure that sits on the ground also helps provide stability to the structure

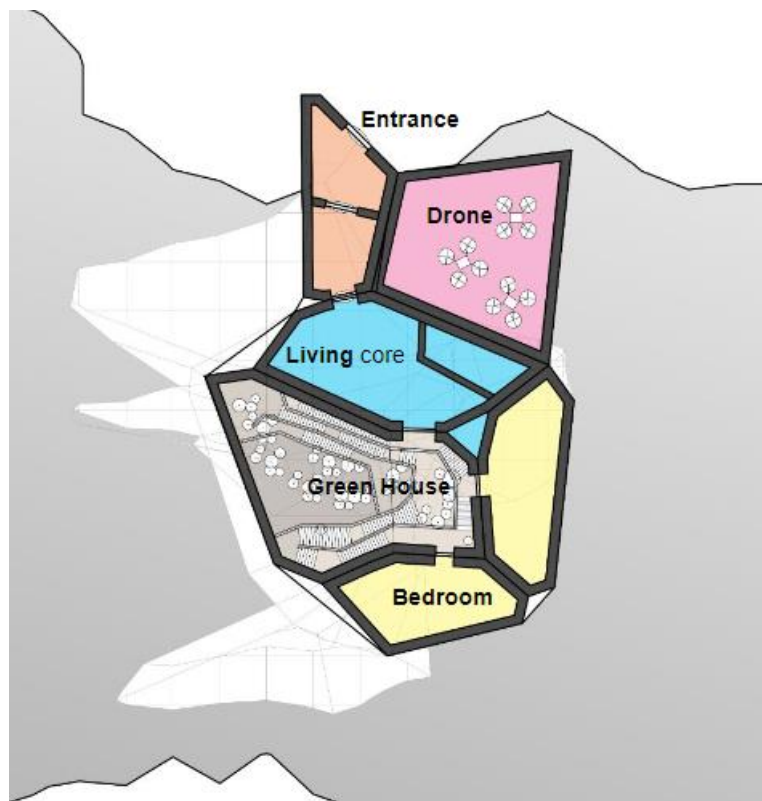

Fig 5. Spatial Zoning

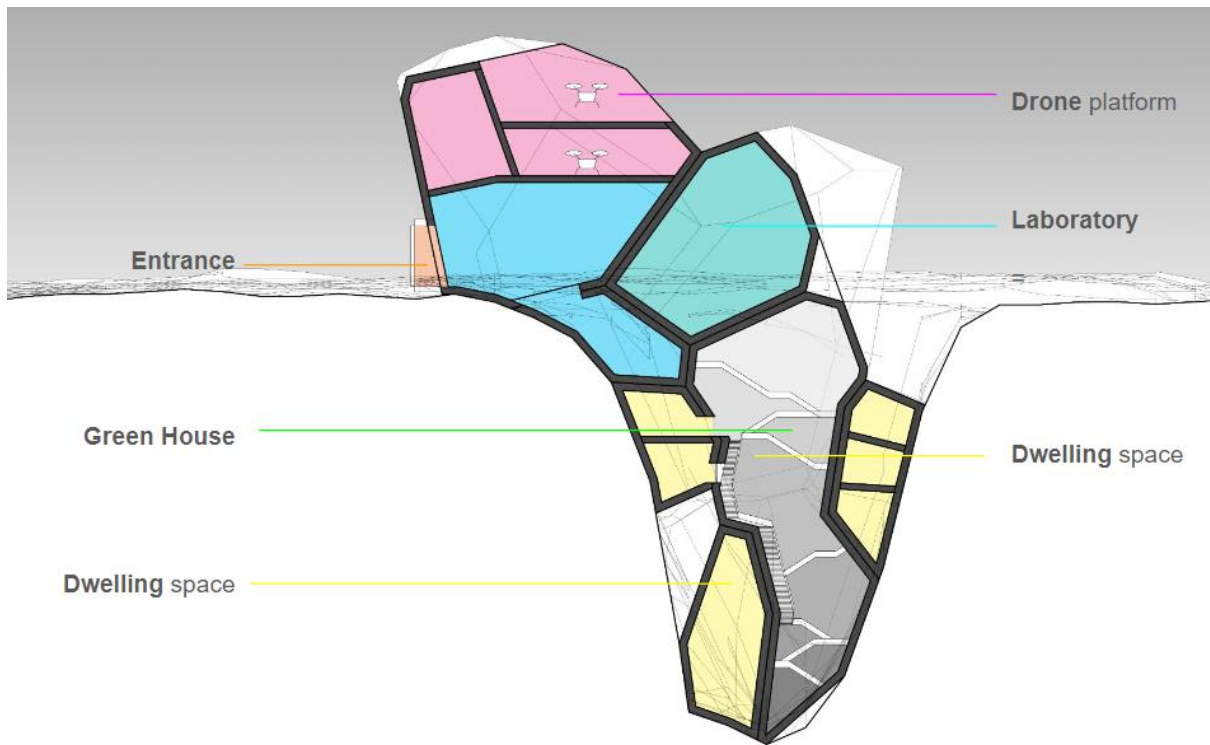

Fig 6. Spaces around the atrium

VISUALISATION



Fig 7. External view of the habitat

DESIGN-TO-ROBOTIC-PRODUCTION(D2RP)

The production process kicks off by breaking down the habitat and canopy into smaller fragments(macro), allowing for the identification and prototyping of individual components. For this, a wall or an element of the structure is chosen which is the part (meso) of the Macro element. These cells from Macro are then grouped in threes to fit a specific form factor, dictated by the milling step forming the Micro components. Five of such groups are chosen that can be held together horizontally. This form factor corresponds to the bounding box of the eventual milled form. Once the components are singled out, the milling pre-processing phase begins.



1.Selection of Individual Wall

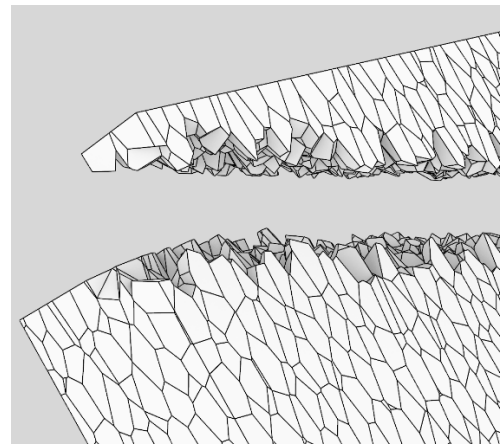

2. Generating Component Cells

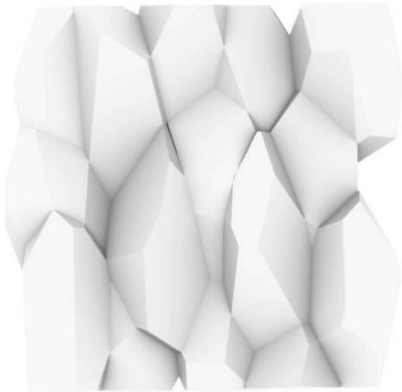

3. Horizontally placed components

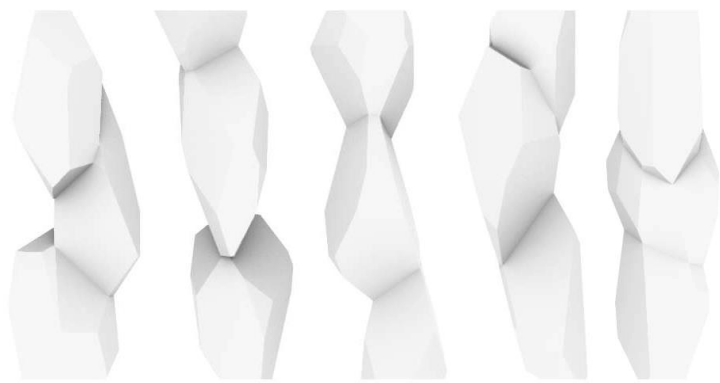

4. Selection of 5 Components

Fig 8. Steps to generate cell components from the wall unit

Initially, each component's optimal orientation is determined, and a 'vacuum-seal' mesh is crafted for every side to ensure unobstructed milling access. Components are approached from two sides, with material gradually shaved off to approximate the final shape. The bounding box is approximately 300x200x700 in size. Tool paths, generated in Grasshopper3D, guide the milling process.

Process for milling components:

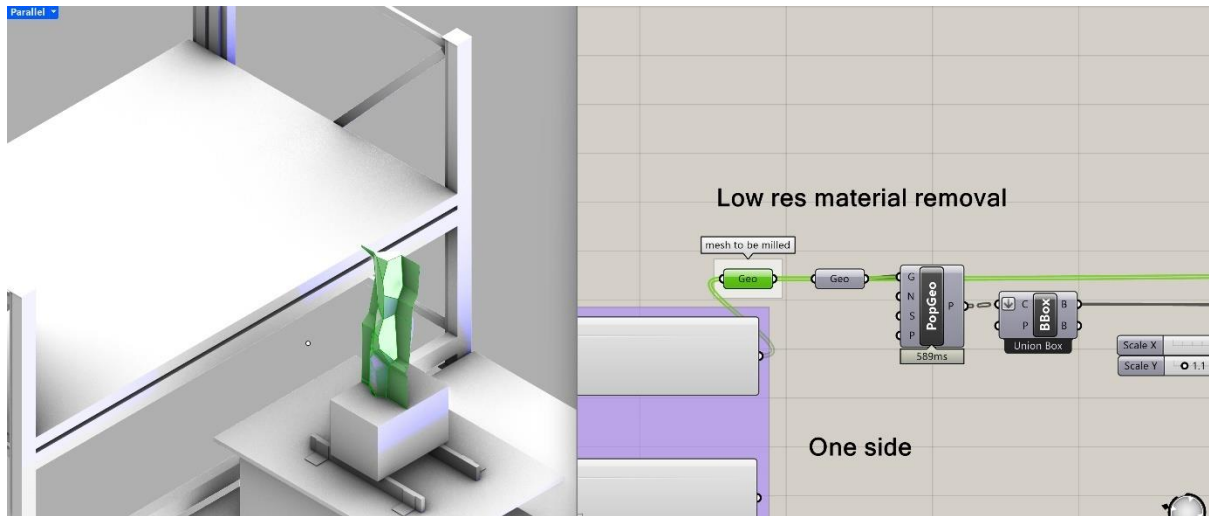

Step 1: Setting multiple 'vacuum-seal' meshes and geometries of the components

The KUKA 6-axis production robot, equipped with a drilling mill, executes the milling without safety sensors. To prevent collisions, a clear workspace and modeled obstacles are ensured. Collision checks are performed on each tool path to safeguard against damage to components, the environment, or the robot. Alignment is crucial, with the initial block positioned to match the computer-modeled bounding box in the robot's frame of reference. Keeping the block stationary throughout prevents misalignment issues.

Material removal begins with swift, coarse steps, progressively moving inward in uniform increments. Each layer brings the component closer to its final form. Initially, only one side of the material is milled, followed by a pass for finer detailing. This process is mirrored on the opposite side, resulting in the finished component.

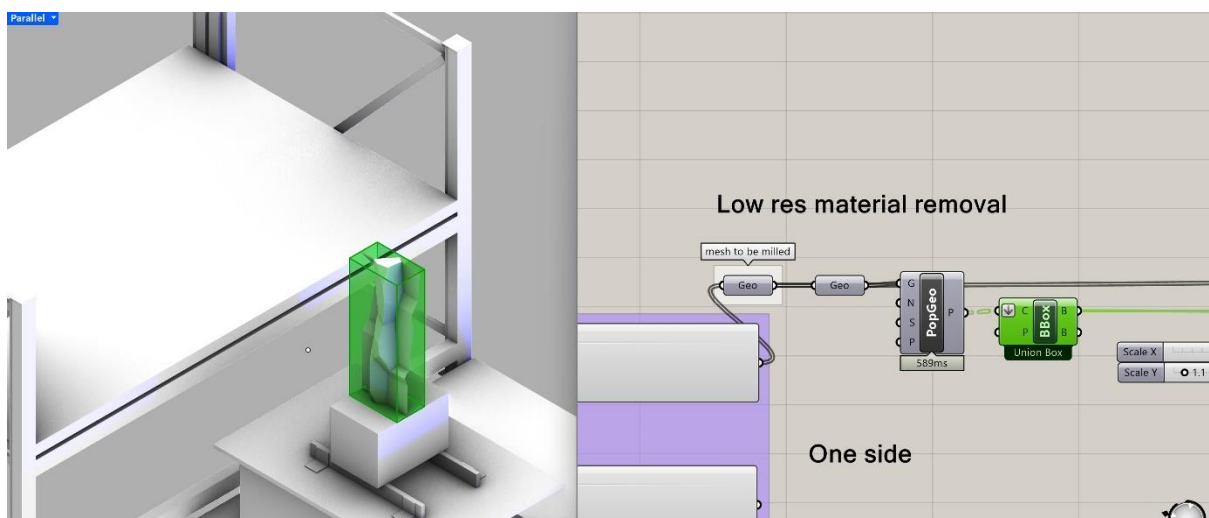

Step 2: Set the bounding box and one geometry

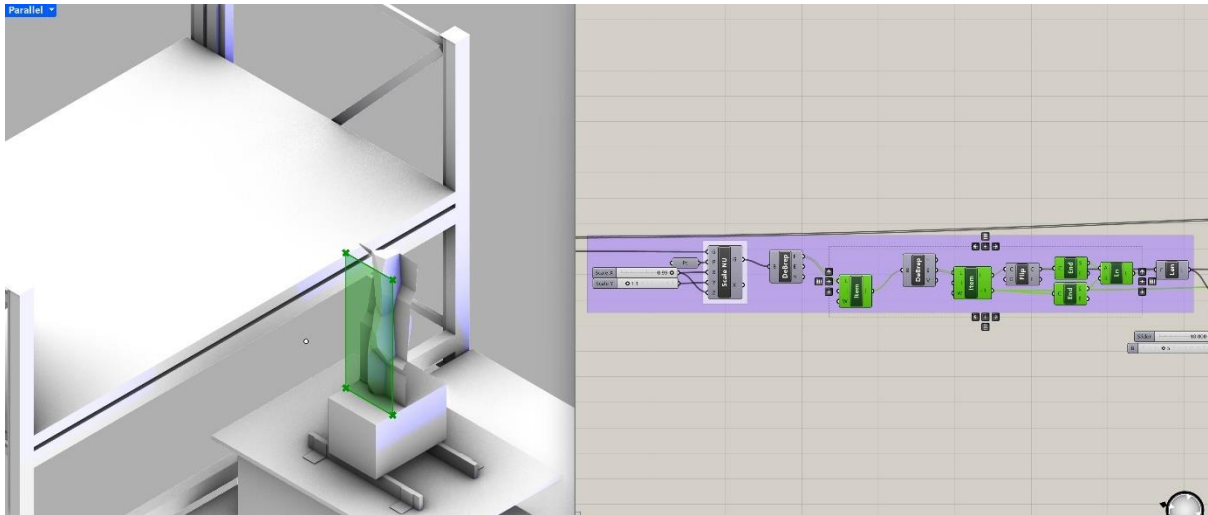

Step 3: Turning the geometry into meshes

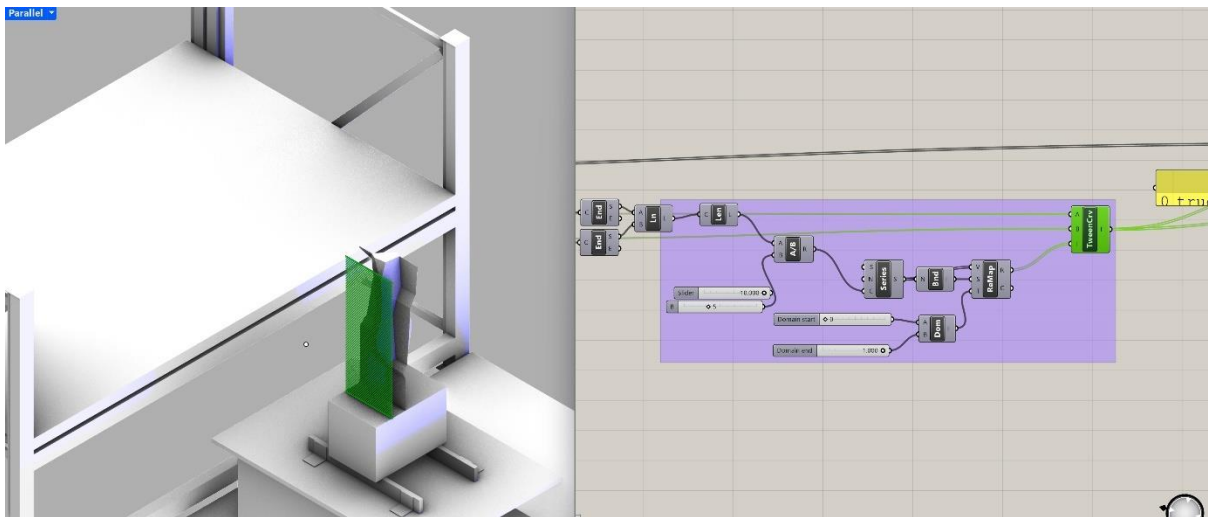

Step 4: Setting the horizontal curves and redefining the milling path

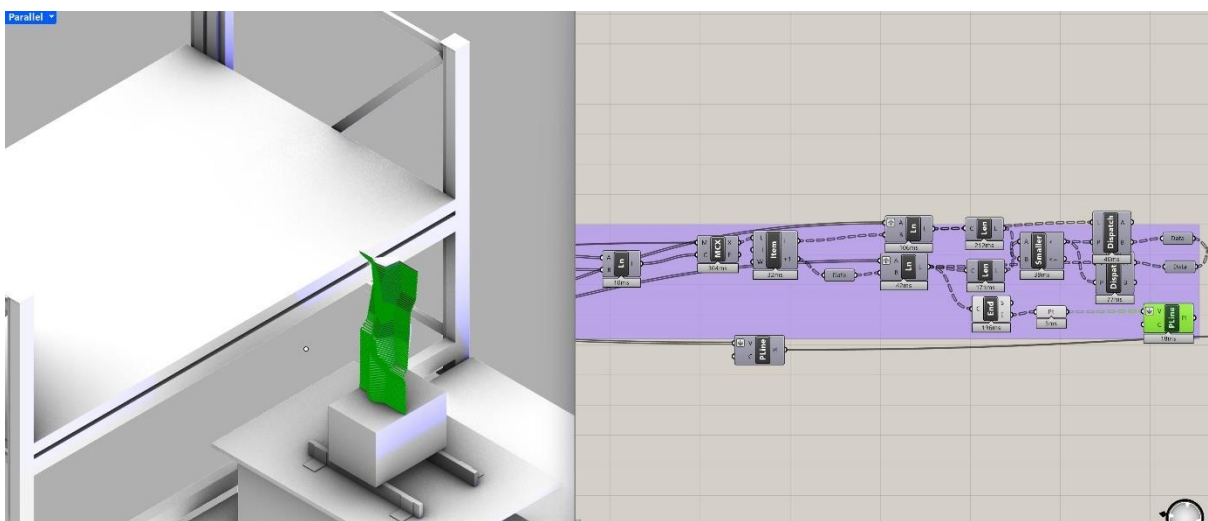

Step 5: Horizontal curves along the geometry

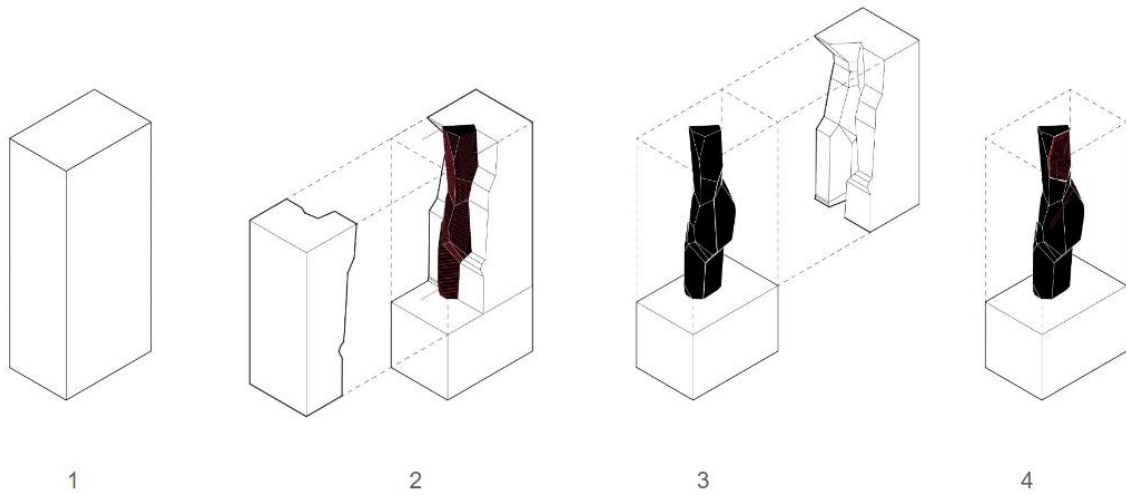
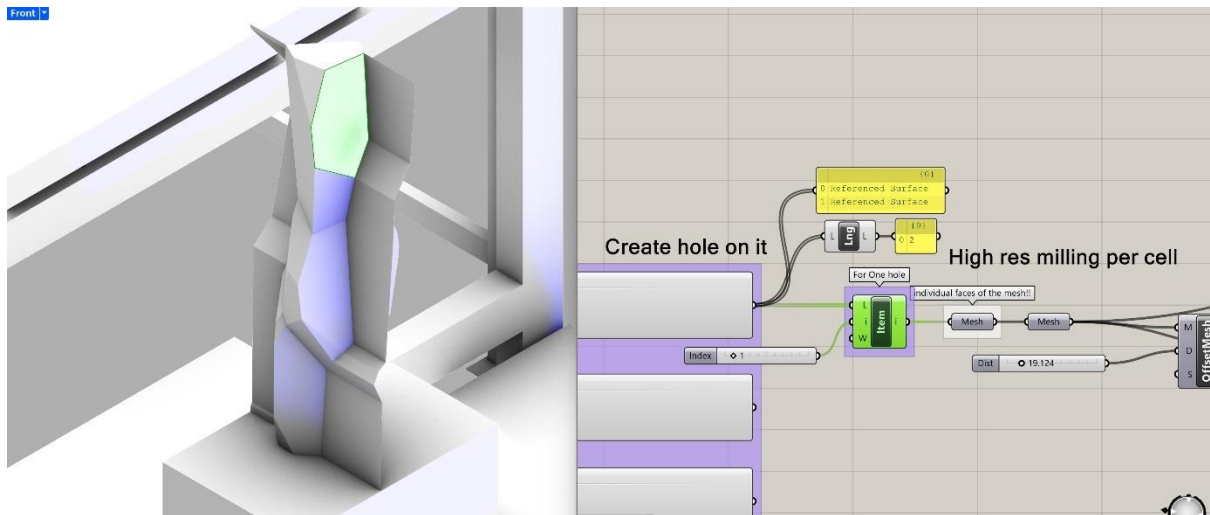
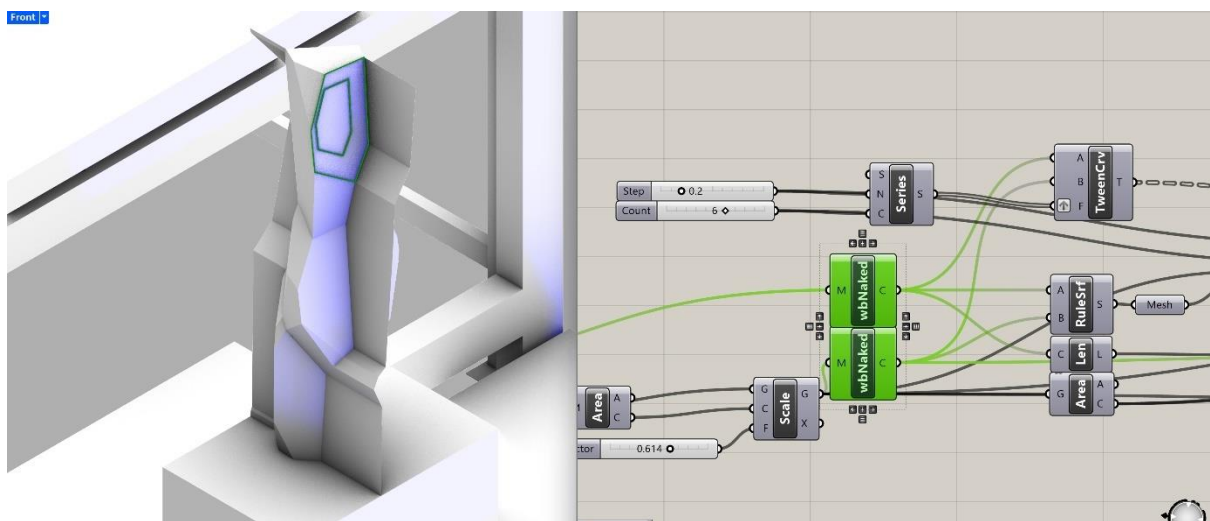

Fig 9. Drilling toolpath process from bounding box to component

Process for milling the components:



Step 1: Choosing the side of the component based on alignment



Step 2: Determining the size of the hole

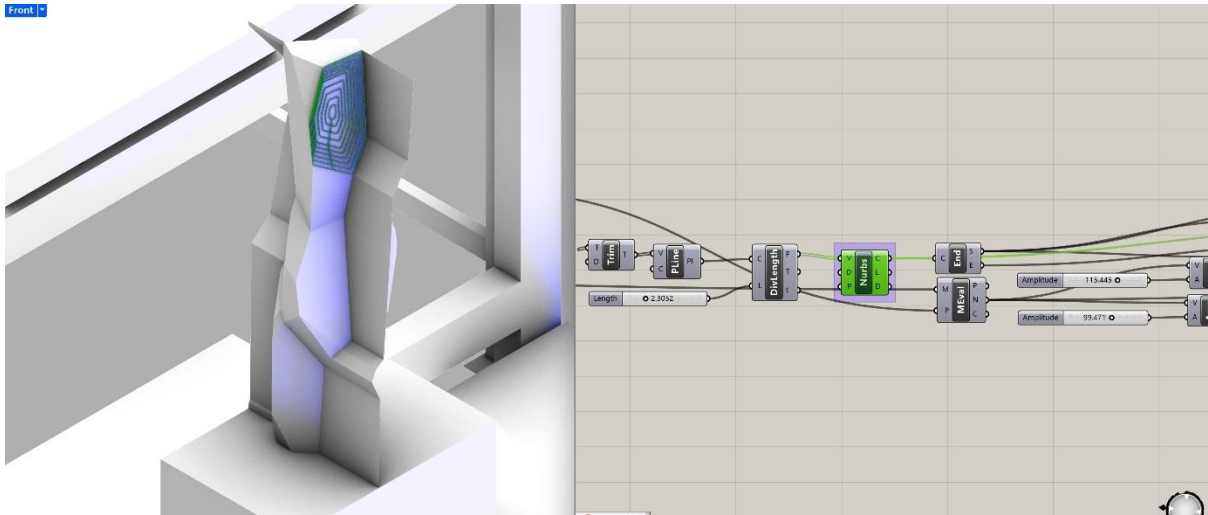

Step 3: Choosing the side of the component based on alignment

Lastly, in anticipation of Human-Robotic Interaction, holes are created for component assembly. Tool paths are designed to deepen the topography of selected faces, creating grip able edges.

HUMAN ROBOTIC INTERACTION

After the components are recognized through computer vision, they are then integrated in place through Human- Robotic- Collaboration (HRC).

HUMAN ROBOTIC ASSEMBLY SET UP



Fig 10. HRI Set up

- Camera: It is a part of computer vision to identify the location of the components in relation to the component and the table.
- Marker points: Here, grey chart was placed on the table and its end coordinates were to be identified by the camera and translated to the computer as location points for the robotic arm.
- Grip location: The robotic arm follows a defined path through set of coordinate points to the location where it can grip the component in a secure and balanced way.
- Point of origin and end point: These points are generated after computer vision by providing the coordinates and defined path for the robotic arm movement from the origin to the endpoint.
- Size of component and distance from the table: To reduce crashing between the component and the table, the robot should have this information when generating the path between points.

HUMAN ROBOTIC ASSEMBLY PROCESS

1. The robot must accurately locate the frame and table by providing the coordinates of each vertex of the frame and capturing corresponding images with the camera to mark their positions in the computer.
2. Safety protocols necessitate, defining specific mid-air node points to guide the robotic arm's movement and limiting its speed to minimize potential damage in case of accidents.
3. Precise and relative positioning of cells is crucial for integration. For instance, when moving a cell to the right of another, the robot's hand should grasp the right side to avoid collisions with the left cell. Additionally, the robot should slow down as it approaches the target cell.
4. Due to inaccuracies in translating 3D vision from the camera into a 2D control frame on the computer, simply pointing to the component hole does not guarantee the robot arm's exact placement. Calibrating for height discrepancies requires human collaboration.
5. Upon reaching the hole, the robot hand is provided with human instructions on how to grasp it and the appropriate force needed to lift the component.
6. The robot arm with human support to balance the component, moves towards the other components based on the coordinates provided and places the components together. The arm is slowed down and stiffness in it reduced to place the component down.

REFLECTION

The experience highlighted the interactive collaboration between humans and robots, revealing the extensive information and cognitive abilities required by robots to execute seemingly simple tasks, such as object manipulation without causing disruptions. Working with two KUKA robots, one involved in milling and the other in HRI processes, also revealed significant differences. The HRI Robot displayed heightened responsiveness to human interaction and precise motion control. This was possible with the deployment of extensive cameras or sensors along the robotic arm to create a comprehensive 3D vision, to avoid collisions and damages. However, imperfections in its settings were observed during practical use, leading to occasional mishaps such as failed object grasping and misjudgments of its own weight, resulting in collisions with the environment. Moreover, the reliance of robotic arms on software and programming introduces potential points of failure, stemming from human errors, software bugs, or

programming language/environment issues. Maintaining robust software integrity is crucial to prevent operational failures or malfunctions that can compromise task execution.

We learnt through the experience that robots play a crucial role in revolutionizing the architectural landscape by overcoming human physical limitations. They excel in tasks that are hazardous, physically demanding, or require intricate precision. For instance, robots effortlessly handle the lifting of heavy regolith components and the fabrication of complex or intricate polygonal shapes and their tireless efficiency in repetitive tasks, not only accelerates project timelines but also reduces the physical burden on human workers. This adaptability extends to tasks of various scales, from fine-texturizing complex component cells to constructing large-scale Voronoi structures. By delegating these physical tasks to robots, human workers can shift their focus to intellectual and supervisory roles, thereby enhancing overall work quality while minimizing injury risks.

However, despite their remarkable capabilities, robots face limitations in intellectual autonomy, relying heavily on human guidance and intervention, especially evident in human-robot interaction (HRI). Human assistants play crucial roles in designating work areas, manipulating objects, and preventing errors or accidents. Consequently, complete automation of robots can be dangerous, therefore emphasizing the need for a collaborative approach. Through computational programs facilitating human-robot communication, we bridge this gap, translating human intent into precise data for robotic execution. This collaborative model not only enhances efficiency but also fosters innovation, enabling robots to serve as valuable assistants rather than replacements. In fields like bricklaying and parametric construction, where precision and complexity intersect, human-robot collaboration holds immense promise. By leveraging robots for tasks requiring precision and repetitive actions, while humans oversee and provide creative input, we can unlock new dimensions of architectural excellence without reducing human values in process and propel the industry forward.

CONCLUSION

In conclusion, the experience of working with Design-to-Robotic-Production and assembly has illuminated numerous avenues for architects to explore in large-scale, complex projects. This endeavor has not only cultivated skills in computational design but has also underscored the inherent advantages and limitations of such approaches. While the utilization of Voronoi systems has showcased innovative spatial possibilities, it has also revealed constraints in flexibility and cell linkage. Our design, aimed at creating a green atrium for sustainable habitation on Mars, evolved to utilize regolith exclusively, facilitating robot-assisted construction. The interaction between humans and robots emphasized the need for enhanced robot autonomy, particularly in extraterrestrial environments like Mars, where human assistance may be limited. Therefore, the imperative lies in augmenting robot self-sufficiency to streamline human collaboration rather than supplanting it entirely.

BIBLIOGRAPHY

Block, I., & Block, I. (2017, October 23). Stefano Boeri imagines dome-covered Mars colony with “vertical forests.” Dezeen. <https://www.dezeen.com/2017/10/23/china-new-shanghai-mars-space-vertical-forests-stefano-boeri-architects/>

Hourglass – DECA architecture. (n.d.). <https://deca.gr/project/hourglass/>

Shared:2023W4G2Design- cs. (n.d.). <http://cs.roboticbuilding.eu/index.php/Shared:2023W4G2Design>